

USER`S MANUAL
MODEL MRM-S
ASSYMETRICAL 3 ROLLS
PLATE BENDING MACHINE



GENERAL NOTES

1. Introduction

Thank you for choosing us. We are proud to have you in our long list of satisfied customers all over the world.

This User's Manual is absolutely for your safety and is essential for the machine to have a long production life. As long as you keep up with our Manual you will be able to run your machine smoothly and safely. Keep in mind that the machine is designed absolutely to perform maximum safety and for efficient working.

In this Manual you can find instructions and information about:

- *Correct installations of the machine*
- *Description of the functional parts of the machine*
- *Set-up and start-up adjustments*
- *Correct standard and scheduled maintenance*
- *Simple safety regulations and accident prevention.*

Therefore, as far as the user's safety is concerned, in this handbook the possible risks connected with machine operation are pointed out as follows:



Attention: *Showing the risks of accident, if instructions are not followed.*



Warning: *Showing the probable damages to the machine or equipment, if the instructions are not strictly followed.*



Note: *It gives useful information.*

*It is certainly necessary that the operator should read and understand all the **Attention, Warning, Note** specified in this Manual before starting with operation of the machine and before any lubrication or maintenance intervention*

On all steps of installation, operation and maintenance safety must be your first concern for the protection of yourself, other users and the service of the machine. In case of any failure please first refer to this Manual, and then if a solution cannot be found contact first of all the distributor where you purchased our product. Do not forget to refer to the drawings and the numbers for any spare part needed or to define any problem. Make sure you have the serial number and production year of the machine.

Our technical staff will make their best to help you in the most convenient way.

2. Transport

As soon as you receive the machine, check for any visible transport damages. Should there be any visible damages; report it straight away to the transporter company and of course to us or your supplier.

Remove any protective crates around the machine and read the instructions on related chapters of this Manual carefully to set up the machine. If the machine is damaged while transport, **immediately take some photographs for insurance claims.**

Take precautions while loading / unloading or moving the machine to avoid any injuries. Refer also to related chapter of this Manual for the best way of handling the machine.

3. Electrical Information

All necessary connection procedure can be found on this Manual. Do not try to connect the machine before reading these procedures and fully understanding the drawings. For any unclear matters get in touch with us or any of our distributors. Have the machine connected by a qualified electric technician. For, as we made clear in the “general conditions of guarantee”, under no circumstances installing mistakes, including electrical connection mistake, can not be covered by guarantee agreement. Always turn off power before making any connections or disconnecting the machine.

4. Maintenance

Your machine is designed and produced to work efficiently and smoothly. To achieve this you should also take care while operating the machine. Regard Maintenance sections to have the longest life from your machine. Try and use original spare parts where necessary and most importantly do not overload the machine or do not make any unauthorized modifications.

5. Safety

Take all precautions possible to avoid any personal injury while using the machine. Keep in mind to protect the third party people around the machine. Refer to safety directives.



GENERAL WARRANTY TERMS

- *Your machine is covered by manufacturer's guarantee for a period of 12 months from the date of purchase against manufacture defects. The warranty period does not exceed 18 months from the date of delivery from the manufacturer's factory.*
- *Warranty covers only manufacture defective parts and / or components that are reported as "defective" by a our company or the Agent Technician and must be reported to in writing by fax or email.*
- *The manufacturer is responsible for the supply of free of charge spares only and cannot be held responsible for loss of work.*
- *Shipping and customs fees for the spare part must be paid by the end-user.*
- *If a technician travel is necessary will not charge for labor and workmanship costs but the customer must pay traveling and accommodation charges.*
- *A Warranty claim does not relieve the Customer from payment obligations.*
- *The Customer can not ask or demand any reimbursement of damage nor the Customer will have the right to extend or delay payment obligations nor the cancellation of order and the refunding of damages as the guarantee is given for the defective parts of the machine and not for the job.*



Note: *All warranty claims must be applied with the Model, Serial Number and the Manufacture Year of the machine.*

TRANSPORT AND LIFTING OF THE MACHINE

Use necessary cranes and lift as shown. Please take extra care during lifting and moving. If necessary consult with specialized companies for lifting.

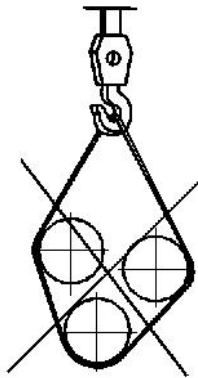

FALSE

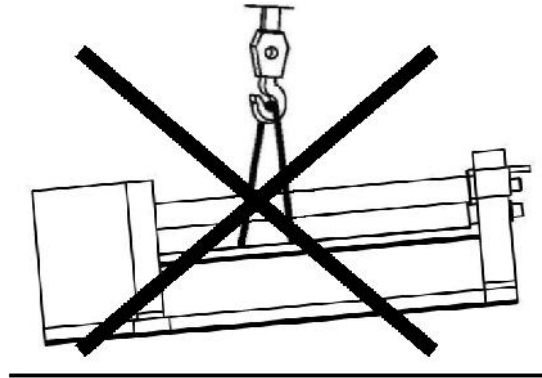

FALSE

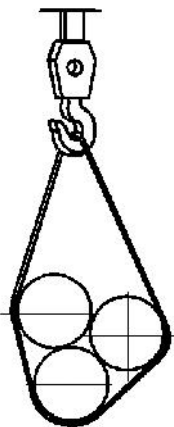

TRUE

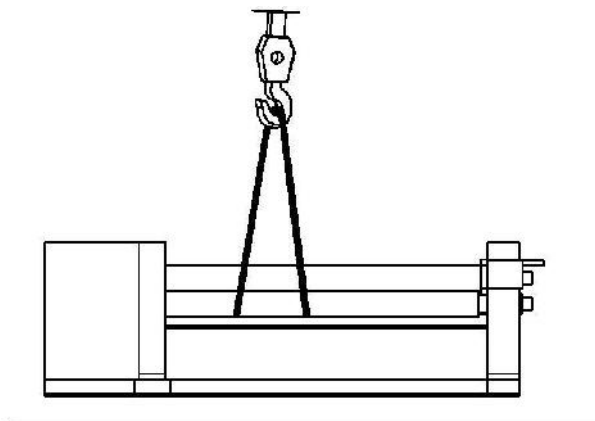

TRUE

OPENING THE PACKAGE

If any visible damage exist on the machine when you receive the machine immediately informs the dealer or manufacturer. Also never forget to state the visible damage on transport documents.

The packing material is completely safe and do not consist any environmentally dangerous articles. However they must be kept out reach of children as some nylon products in packing may cause suffocation if used as a toy etc.



MRM-S FOUNDATION PLAN

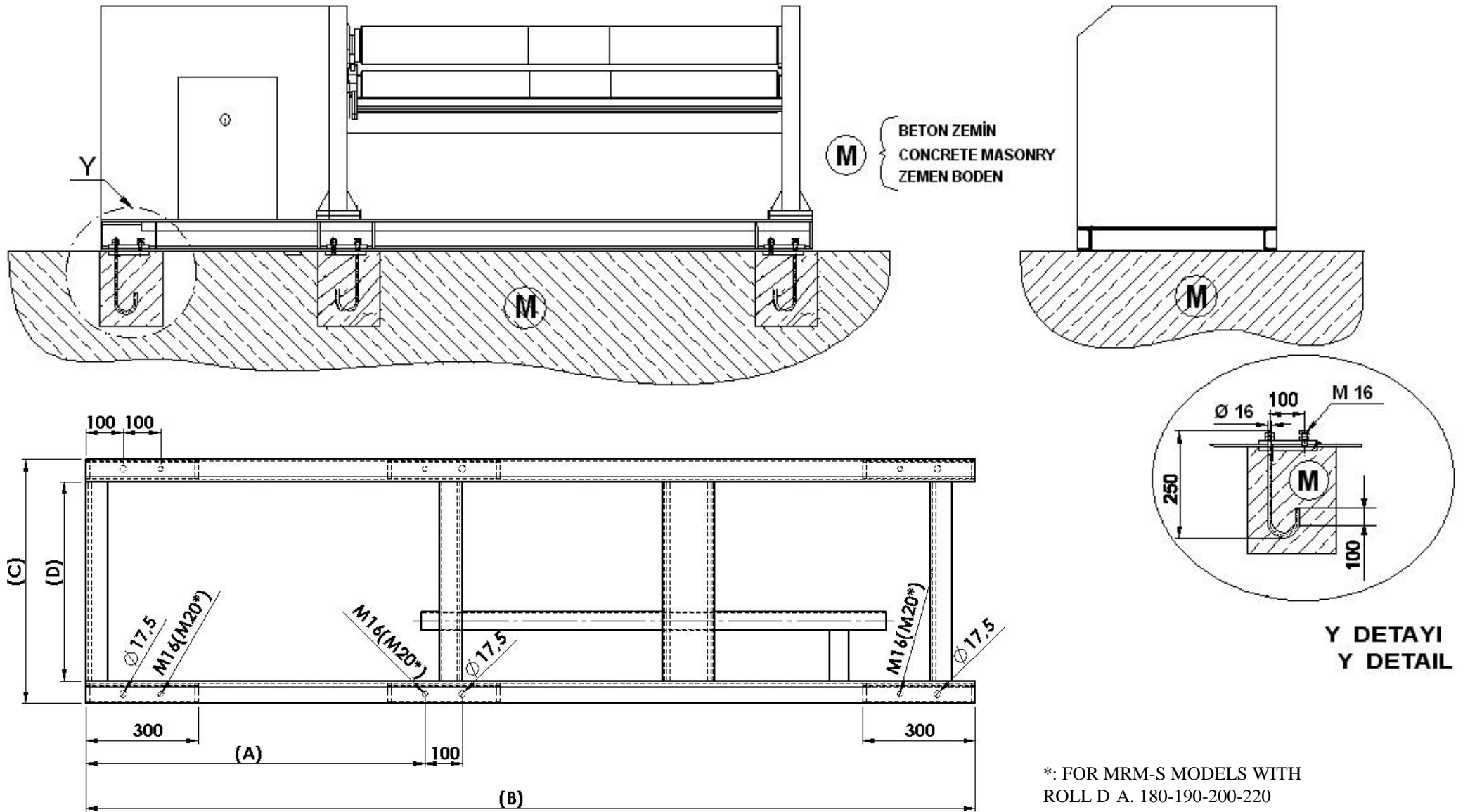

*: FOR MRM-S MODELS WITH
ROLL D A. 180-190-200-220

*Check the next page for dimensions.

Model	A mm.	B mm.	C mm.	D mm.
MRM-S 1050x130	904	2370	650	600
MRM-S 1050x150	904	2390	675	625
MRM-S 1050x170	975	2450	710	660
MRM-S 1050x190	1160	2750	915	865
MRM-S 1550x130	904	2870	650	600
MRM-S 1550x150	904	2890	675	625
MRM-S 1550x170	975	2950	710	660
MRM-S 1550x190	1160	3250	915	865
MRM-S 2050x130	904	3370	650	600
MRM-S 2050x150	904	3390	675	625
MRM-S 2050x170	975	3450	710	660
MRM-S 2050x190	1160	3750	915	865
MRM-S 2550x150	904	3890	675	625
MRM-S 2550x180	1160	4250	915	865
MRM-S 2550x190	1160	4250	915	865
MRM-S 2550x220	1160	4250	965	915
MRM-S 3050x160	975	4450	710	660
MRM-S 3050x190	1160	4750	915	865
MRM-S 3050x200	1160	4750	915	865
MRM-S 3050x220	1160	4750	965	915

MAIN DIEMENSION OF THE MACHINE

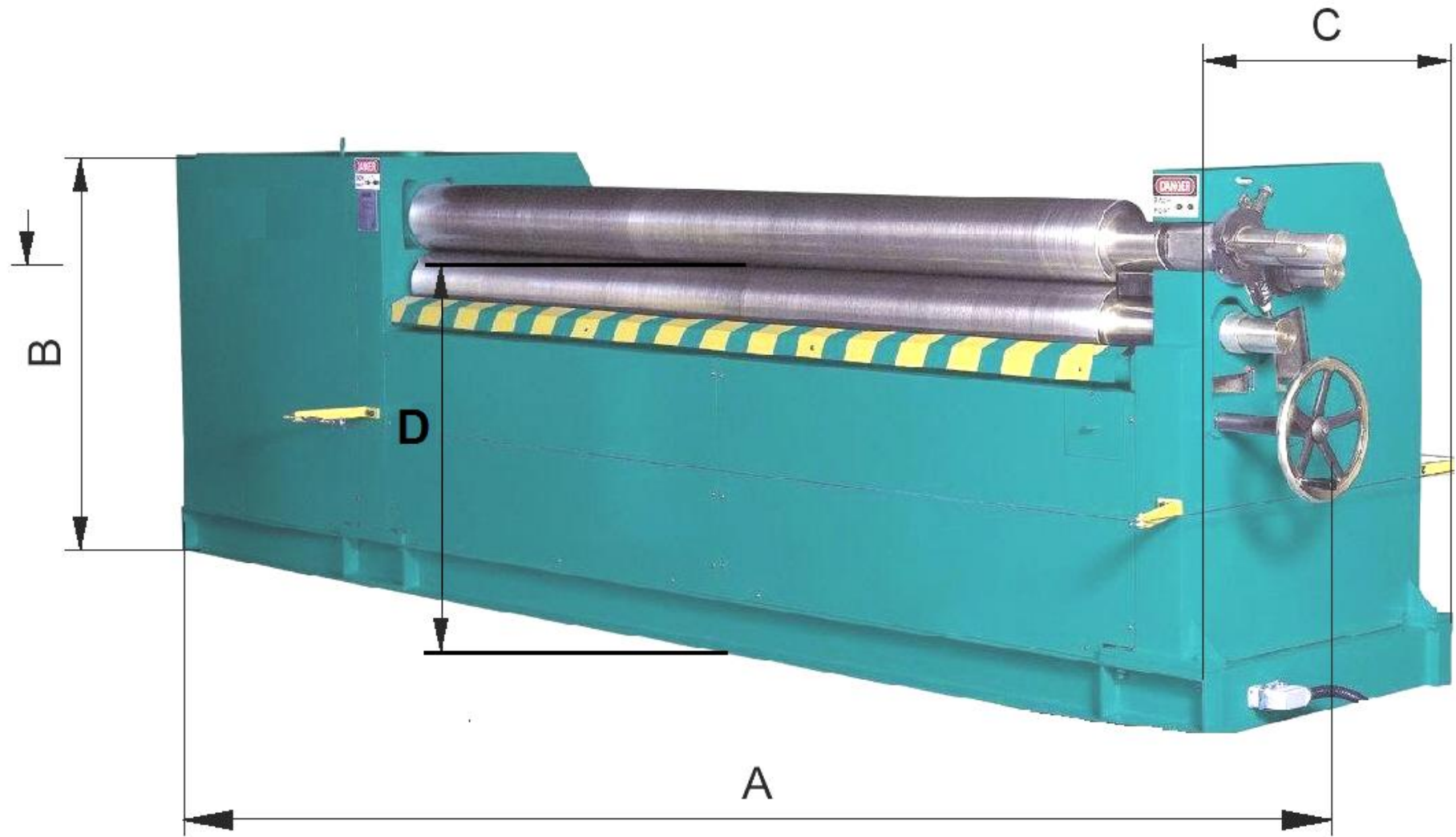

**Check the next page for dimensions.*

Model	Useful Length	A mm.	B mm.	C mm.	D mm.
MRM-S 1050x130	1050	2750	1020	650	757
MRM-S 1050x150	1050	2750	1040	680	750
MRM-S 1050x170	1050	2850	1050	720	713
MRM-S 1050x190	1050	3200	1300	950	899
MRM-S 1550x130	1550	3250	1020	650	757
MRM-S 1550x150	1550	3250	1040	680	750
MRM-S 1550x170	1550	3350	1050	720	713
MRM-S 1550x190	1550	3700	1300	950	899
MRM-S 2050x130	2050	3750	1020	650	757
MRM-S 2050x150	2050	3750	1040	680	750
MRM-S 2050x170	2050	3850	1050	720	713
MRM-S 2050x190	2050	4200	1300	950	899
MRM-S 2550x150	2050	4250	1020	650	750
MRM-S 2550x180	2550	4350	1300	950	904
MRM-S 2550x190	2550	4700	1300	950	899
MRM-S 2550x220	2550	4700	1400	1150	869
MRM-S 3050x160	3050	4850	1050	720	718
MRM-S 3050x190	3050	5200	1300	950	899
MRM-S 3050x200	3050	5200	1300	950	894
MRM-S 3050x220	3050	5200	1400	1150	869

TECHNICAL PROPERTIES

The MRM-S Model Mechanical Three Roll Benders have these specifications:

TECHNICAL SPECIFICATIONS AND STANDARD EQUIPMENTS

- *Two rolls powered by a single chain or belt driven worm type gearbox and gear system*
- *SAE 1050 Quality certificated steel rolls with high tensile strength*
- *Steel welded main frames*
- *Mobile control panel*
- *Conical bending device*
- *Central lubrication*
- *Precision bending with brake motor*
- *Motorised adjustment of back roll*
- *Worldwide available components used in production (Telemecanique, Siemens for electric)*
- *User manual book*
- *Built according to EC safety directives(CE – Mark)*

OPTIONAL ACCESSORIES

- *Digital read-out for rear roll*
- *Induction hardened rolls*
- *Extended roll shafts for profile and pipe bending*
- *Profile and section bending rolls*



Warning: *Do not feed profiles having a higher thickness than specified for the capacity of the machine. Do not feed more than one piece at a time. Do not use the machine for any other job the one for which it has been designed.*

MODEL	Working length	Prebending capacity*	Bending capacity	Roll diameters Ø	Min. bending dia Ø	Main motor power	Back Roll motor	Length	Width	Height	Weight
	mm	mm	mm	mm	mm	kw	kw	mm	mm	mm	kg
MRM-S 1050x130	1050	6	7	130	195	2,2	1,1	2750	650	1020	1200
MRM-S 1050x150	1050	7	8	150	225	3	1,1	2750	680	1040	1450
MRM-S 1050x170	1050	8	9	170	255	4	1,1	2850	720	1050	1600
MRM-S 1050x190	1050	9	10	190	285	4	1,5	3200	950	1300	2450
MRM-S 1550x130	1550	5	6	130	195	2,2	1,1	3250	650	1020	1400
MRM-S 1550x150	1550	6	7	150	225	3	1,1	3250	680	1040	1650
MRM-S 1550x170	1550	7	8	170	255	4	1,1	3350	720	1050	1850
MRM-S 1550x190	1550	8	9	190	285	4	1,5	3700	950	1300	2750
MRM-S 2050x130	2050	3	4	130	195	2,2	1,1	3750	650	1020	1600
MRM-S 2050x150	2050	4	5	150	225	3	1,1	3750	680	1040	1885
MRM-S 2050x170	2050	5	6	170	255	4	1,1	3850	720	1050	2100
MRM-S 2050x190	2050	6	7	190	285	4	1,5	4200	950	1300	3100
MRM-S 2550x150	2550	3	4	150	225	3	1,1	4250	650	1020	2150
MRM-S 2550x180	2550	4	5	180	270	4	1,5	4350	950	1300	3050
MRM-S 2550x190	2550	5	6	190	285	4	1,5	4700	950	1300	3400
MRM-S 2550x220	2550	6	7	220	330	5,5	2,2	4700	1150	1400	5000
MRM-S 3050x160	3050	2	3	160	240	4	1,1	4850	720	1050	2650
MRM-S 3050x190	3050	3	4	190	285	4	1,5	5200	950	1300	3750
MRM-S 3050x200	3050	4	5	200	300	4	1,5	5200	950	1300	4000
MRM-S 3050x220	3050	5	6	220	330	5,5	2,2	5200	1150	1400	6000

SAFETY DIRECTIVES

The three-roll plate bending machine is supplied with necessary guards to protect from injuries by worm-type gearbox and other gears. The only other area which needs to be carefully monitored during use is the rotational area of the rolls.

Also abuses and misuses risk the following:

- *Serious injury of the user*
- *Serious damage to the machine*

All persons who is in of the machine should carefully read and fully understand this manual for the of benefit themselves.

This is for your safety !



Attention:

- *Never try to bend very hard or fragile material on the machine (e.g. hard steel, glass)*
- *Any modification on the machine without written confirmation from the manufacturer is strictly forbidden as such changes in the machine can cause unintended damages and injuries.*
- *All orders and advises in this machine should be strictly obeyed for a safe working environment.*

DANGER ZONES

The below shown danger zones must be kept clear during operation

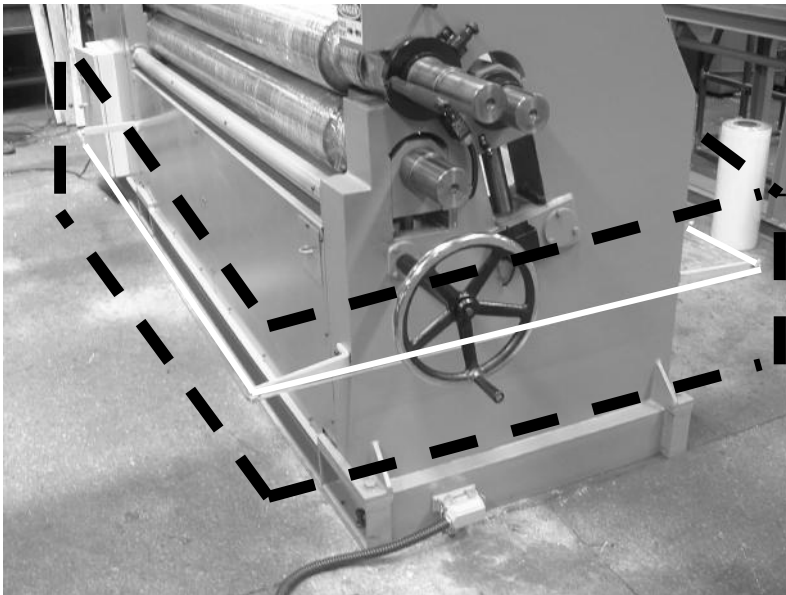

NOISE: *The noise of the machine is about <70 dB.*



EXPLANATION FOR OPERATOR

Operator under age of 16 years to operate the machine is strictly forbidden (EC-Directive). The operator of the machine should carefully read this manual and understand the danger he might be in if he misuses or abuses the machine. If any part of this manual is unreadable or illegible please contact to the dealer and manufacturer

The owner of the machine should be responsible for operating the machine with qualified personnel.

PERSONAL PROTECTION

Gloves and safety glasses and safety cap are recommended during operator.



Attention:

- > No material should be fed if the machine is running.
- > All emergency stop must be easily accessible.
- > The user must be careful for third persons entering the operation area of the machine.



Note : If any labels are lost or unreadable contact the manufacturer for new supplies.

WORKING AREA OF THE MACHINE

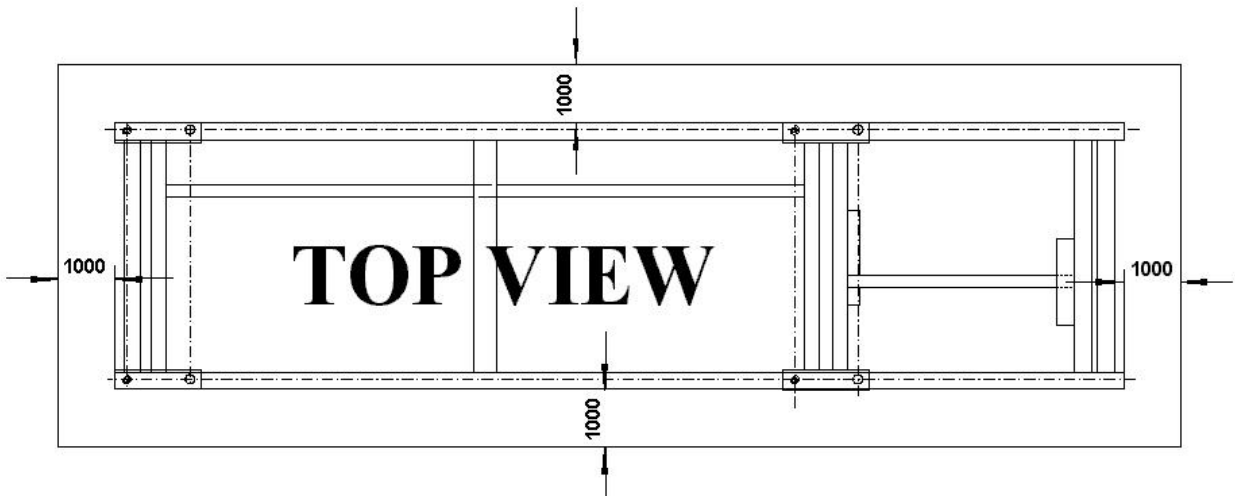

Attention: Before the first use of the machine always check this list carefully for a safe start.

1. Check the emergency stop button on the command panel
2. Make sure that the security wire around the machine is free
3. Check for visible oil leak
4. Control of the buttons on the command panel



SAFETY AND ACCIDENT PREVENTION INSTRUCTIONS

General Safety Instructions

Following instructions are meant for the operator of the machine and it is the End-User's responsibility to make sure the operator reads and understands the following and the User's Manual for safe operation.

- Read the User's manual before operating the machine.
- Never touch rotating or moving parts.
- Always inform electric faults to electric technicians.
- Keep your working dress or long hair or necklace etc away from rotating parts.
- Make sure you know the position of Emergency Stop Buttons on the machine.
- Switch off the machine when **NOT** working.
- Work with necessary safety clothes if necessary (safety shoes, glasses , earplugs etc).
- Control the Safety features before working and ensure they are working properly.
- See and understand Safety Labels on the machine.
- Perform periodic maintenance.
- **DO NOT** overload the machine.
- If you see abnormal behavior of the machine, stop the machine and inform your supervisor immediately.
- Be careful of other people around the machine during operation.
- Never modify electric unit.
- Never remove any mechanic or electronic safety features from the machine.
- Be extremely careful during transport or re-placement of the machine and follow transport instructions in the manual to safety handle the machine.

MOTORISED BACKROLL SAFETY SWITCH

The motorized back roll has a safety switch. When the roll is at its lowest point the switch will stop the motor.

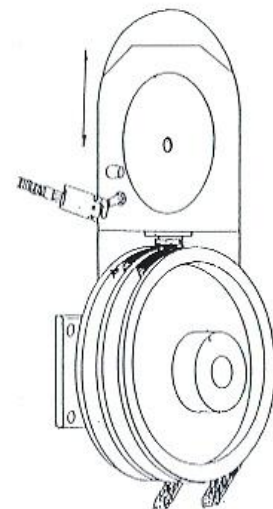

EXPLANATION FOR SAFETY SWITCH

The machine has been equipped with a security switch and wire for the operators safety. When the safety wire is pushed it pulls the below shown ring, this acts as an emergency stop and stops all machine activity.

To restart, pull the blue knob (shown by ① in fig.1) while pulling the safety wire when engaged. You should see green (shown by ② in fig.2) line under the blue knob. Now you can restart the machine from the control panel.

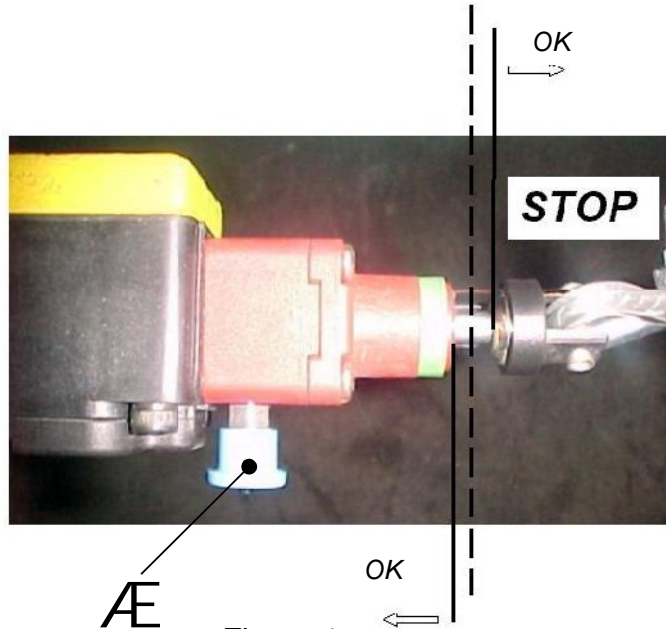
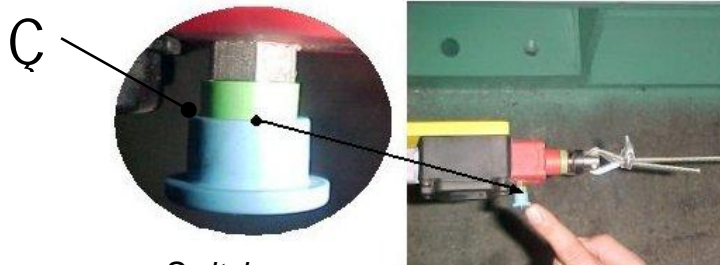

Figure 1

Safety switch's on and off positions as given below.



Switch on position

Figure 2

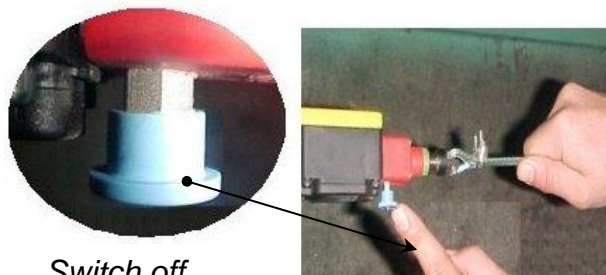

Switch off position

Figure 3

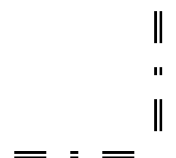

The safety wire comes unassembled for packing reasons and must be assembled by the customer as shown above to completely surround the machine

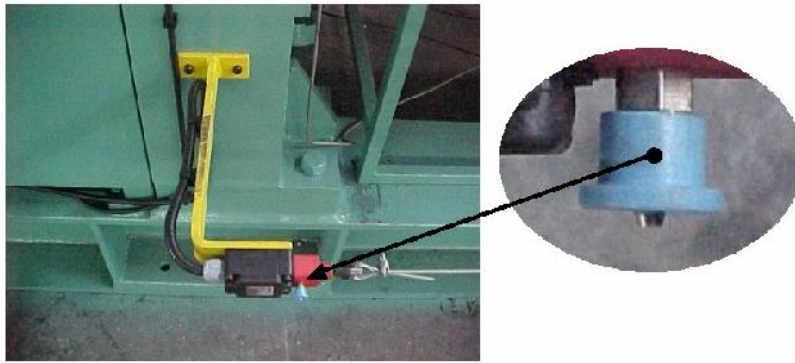

Figure 4



Attention:

The safety wire is an important safety measure and must never be removed while the machine is setup. It should be only removed for transport purposes.

While assembling it is important to fit the wire to the safety switch lock securely as shown below.



Figure 5

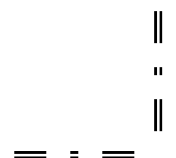

ELECTRICAL CONNECTIONS



Warning :

All electrical connections must be performed and completed by a qualified electric technician in order to minimize chance of personnel injury or damage caused by wrong connection.

The cable must be directly connected to the machine. No intermediates should be used. The following pages contain the necessary diagram of electrical connections.

Ensure that the Electric Net is capable of loading up to V.Double-check the grounding for a safe operation. (look at electricity plan)

ROTATION OF MOTOR

After all the electrics have been completed, start the machine as below and check the rotationary axis of the motor.

- Bring Main Switch to Pos 1
- Bring Key Switch to Pos 1
- Push the foot pedal
- Check the rotation direction axis of the motor

Reverse connect the electrics by qualified electric technician to achieve right rotation direction.



Note : When you push the button of up the roll on the commander control panel, if rolls are moving up (moving reverse position) this means that motor is moving the reverse position. We advise to change the electric cable connecting points.

INSTALLATION FIGURE

Connection of operation plug to machine;



OPERATING INSTRUCTIONS

First Start-Up

- When you see the Power On Indicator press the Start Button. The motor should start up and after a few seconds you should hear the machine running
- Test the movements of the machine by pressing rotation and up-down buttons

Normal Operation

Before starting to operate the machine, when you must to read electric panel's explanation.

A diagram of the Operator's Panel is given below;

1. Start button – To start main motor
2. Emergency stop
3. Back roll – Up & Down
4. Power on indicator – When on this indicates the machine Main Power Switch is on and ready to start
5. Digital display (optional)
6. Rolls rotation – Right
7. Rolls rotation – Left

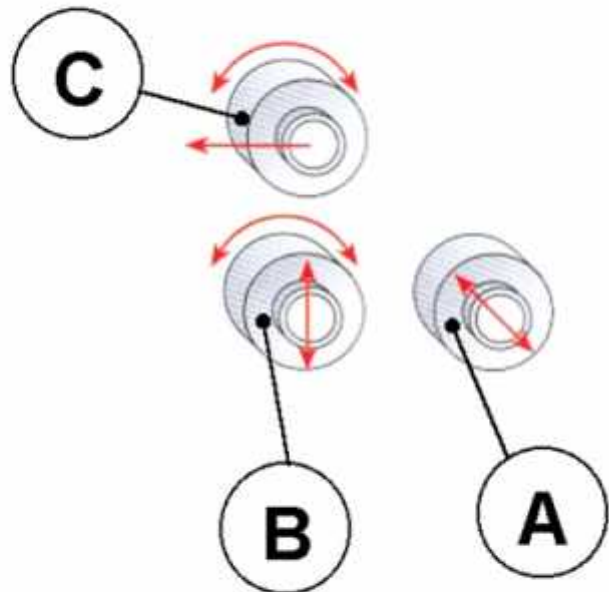

BENDING OPERATIONS

3 ROLL BENDING PRINCIPLES

Because of the heavy materials involved in bending, it must be done by qualified personnel who have experience on such machines. Each step of the bending and pre-bending or conical bending must be done very carefully. Remember that you can always make the radius tighter by bending a little more but once you bend it too much there is no way of turning back.



Note: Before operating the machine, be sure that this manual is thoroughly read and understood by the personnel who will directly operate the machine and others concerned with it.

PRE-BENDING OPERATION

Pre-bending is the operation where the edges of the material is bent to the same radius of the end radius. This is used to get best results in full circle bending (i.e. pipe making)or in operations where there must not be any flat edges. According to the final radius to make the finished material very good.

The pre-bending process is also different compared to 3 roll bending machines. The following steps must be taken to make a pre-bending.

Before operation:

1. *Clean the material and the rolls from dust, or grease*
2. *Make sure there are no chips or flame cutting left-over on the edges of the material*
3. *Keep in mind that if the material is cut by flame that side will be harder than the other side*
4. *Check the surface of the material carefully make sure its flat*
5. *It's a good idea to have template of the required radius when making a bend. To make a template cut a hard cardboard or carton piece with the necessary radius*
6. *Always work in the center of the rolls as shown below.*

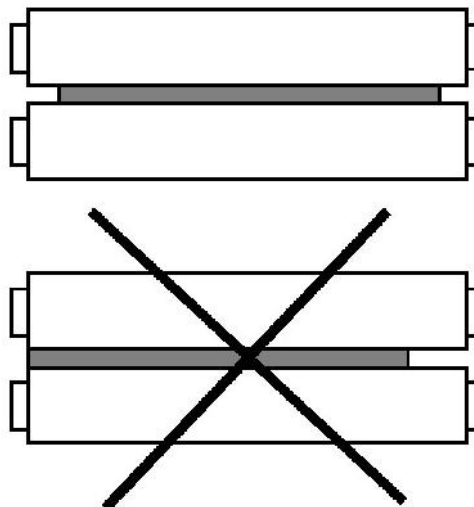

Sheet Bending Position

Figure 1

Top roll and lower roll in a flat position.

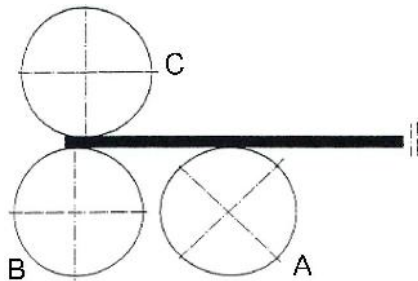

Figure 1

Figure 2

Move the back roll up to complete the pre-bending

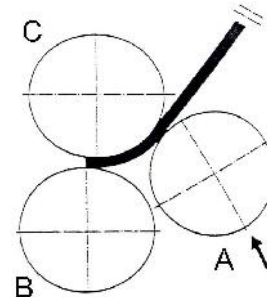

Figure 2

Figure 3

Reverse the sheet and place for second pre-bending.

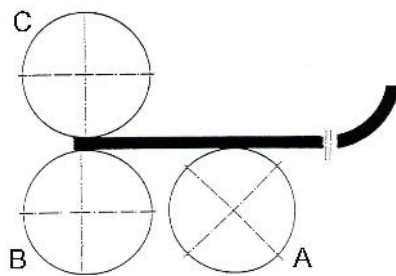

Figure 3

Figure 4

Move the back roll up to complete Pre-bending

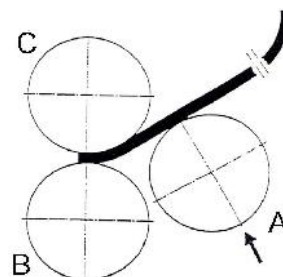

Figure 4

Figure 5

Roll until required diameter is achieved.

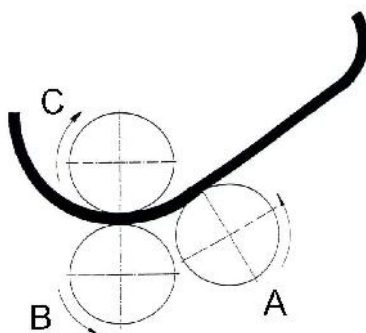

Figure 5

Figure 6

The finish operation shown as below figure 6

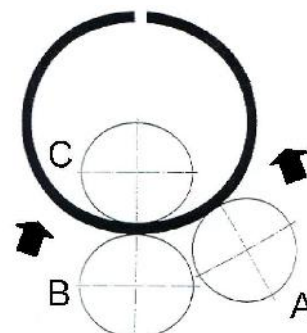

Figure 6





Note: *That the material will progressively harden with each pass.*



Note: *If you are working with stainless steel it is important to finish the job in a few passes. Because the work hardens and it progressively harden after each pass.*

CONICAL BENDING

To make the conic bending operation in the machine, the down roll must oblique position. Please follow these instructions step by step.

- *Down roll must be bottom position*
- *At behind the machine, near the roll there must be a cover in it, please takeoff this cover.*
- *Roll must be oblique position*
- *Opening roll must be oblique position too to make this roll must be up position*
- *To adjust this roll please take off the connections under the cover and it must be get into oblique position (like down rollers)*
- *Now two rolls are oblique position and machine is ready for conic bending*

Please replace the sheet this ready (for conic bending) machine and replace the conic support bars behind the sheet now you can make conical bending.



Attention : *Be sure to clean any oil or grease put on the rolls before operation. If don't work lubrication or lubrication deficiency we don't responsible for lubrication deficiency or don't work damages at last.*



Note: *When bending conical the overall max. thickness capacity decreases by 25 %*



Note: *When cone bending, the thickness and width capacities of the machine are reduced. Check with the distributor or manufacturer for your requirements.*

Because of the extra resistance forces on the rolls while making conical bending the capacity of the machine must be accepted half as usual therefore the max. bending thickness must be reduced to half in conical bends. The conical bending is done by using the attachment on right side of the machine and the tilting of the roll. Please refer to the drawing for a better idea of a conical bend.

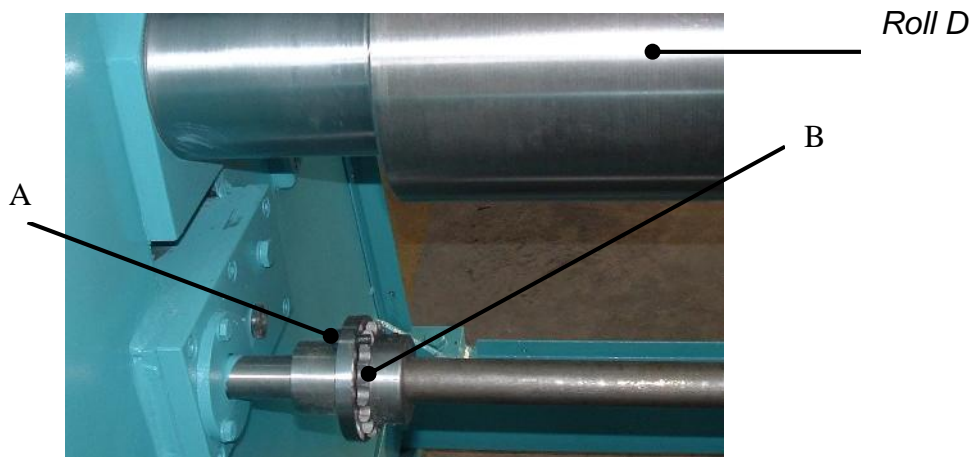
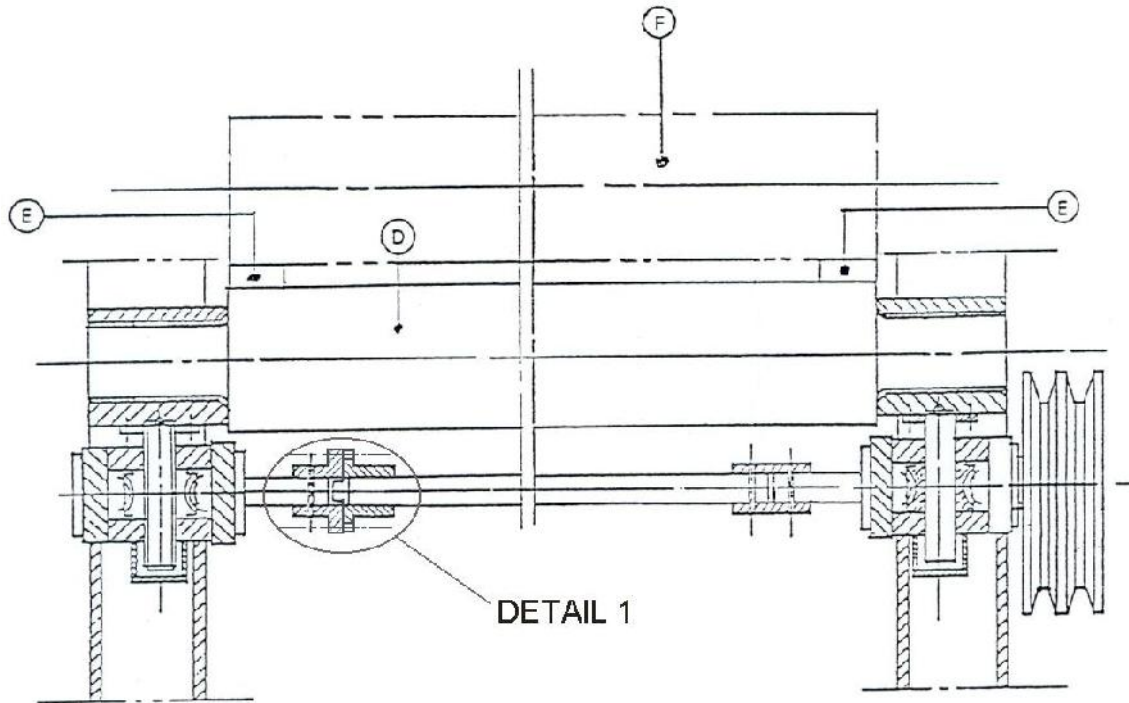

DETAIL 1

- Loosen bolts A
- Detach B connection
- Use the lift motor to tilt the bending roll D

Straightening the D Roll

To straighten the roll D after conical bending you must put straight materials (E) between rolls F and D and reversing the operation above

OPENING THE TOP ROLL

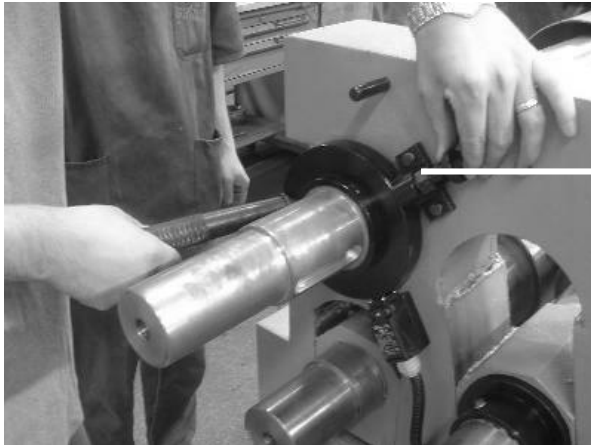

Mechanical
Lock

Figure – 1



Figure – 2

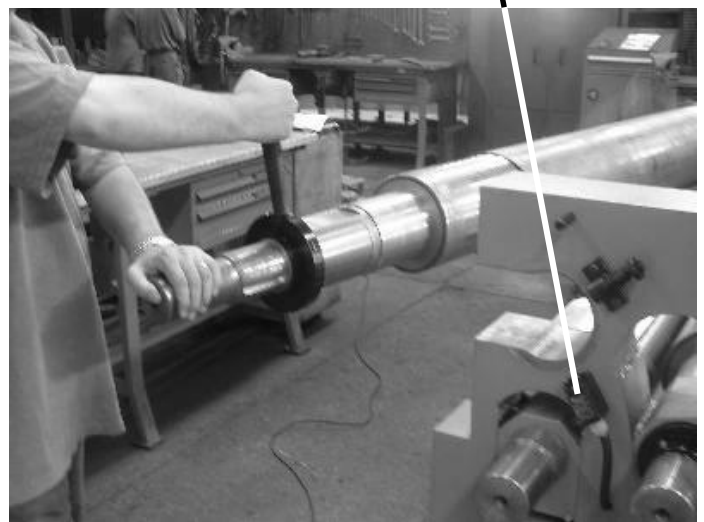

Safety
Microswitch

Figure – 3

Opening the top roll is easy and safe. Once the top roll is open the machine will not function. There is a safety microswitch (Figure – 3) that prevents the machine from operating while the top roll is open.

1. Release the mechanical lock to move the handle on top roll (Figure – 1)
2. Move the handle as far as you can and see that the roll can move in the housing (Figure – 2)
3. Pull the top roll out (Figure – 3)
4. Reverse above steps to close the top roll and make sure the mechanical lock is secure.



Warning:

Do **NOT** modify this safety device. **NEVER** operate any function of the machine while the top roll is open.



MAINTENANCE

PERIODIC CONTROLS

The rolls of the machine must **NEVER** be greased or lubricated. Because, then the rolls will slip the material and will not bend. Always keep the rolls clean and free from grease or any lubricant. Also make sure that the material is free from grease and dirt.

These points must be greased periodically at least once a month or more if daily usage exceeds 8 hours a day. Note that some of these points are actually inside the machine cover and the front cover must be removed in order to reach them. Any standard commercial grease can be used for lubrication.

NUMBER	PERIOD	WHAT TO DO
1- Gear system	Once a month	Grease
2- Gearbox	Once a year	Oil

REDUCTION GEARBOX MAINTENANCE

The reduction gearbox of the machine is inside the front cover and is maintenance free. Only you should control it periodically and tighten the bolts fixing it to motor and to the frame, if necessary.

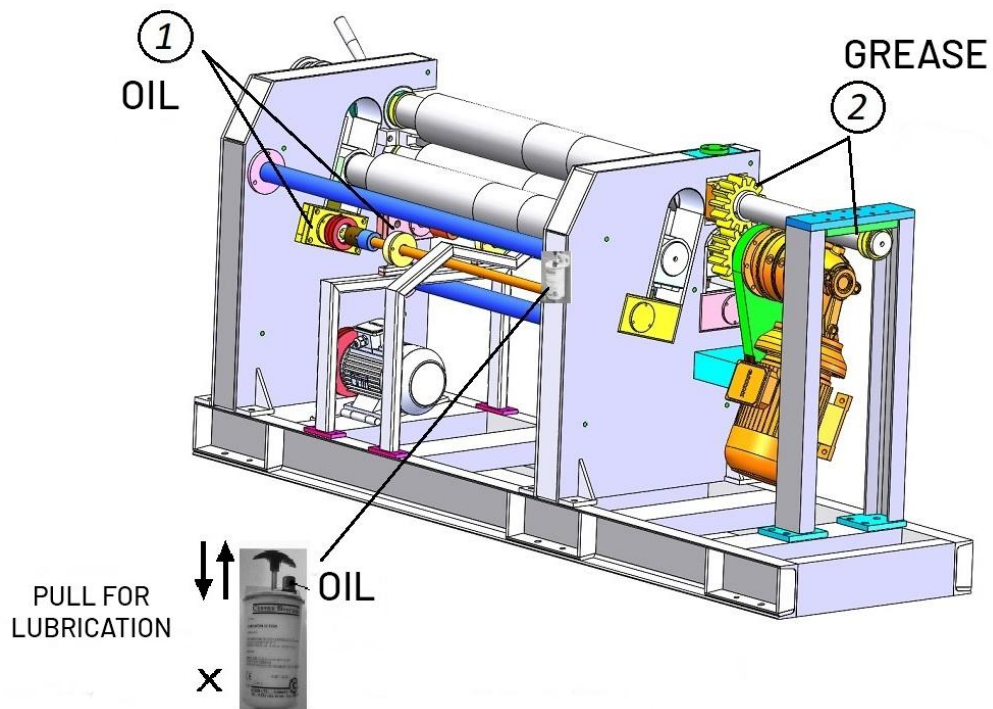

LUBRICATION PLAN

For efficient working with the machine the above marked (1 and 2) parts must be greased at least once a week. Also the (x) marked lubrication pump oil level must be controlled and re-filled if necessary. We recommend Mobil Vectra 2.

The lever on this pump should be pulled up once and it will go down slowly by itself to lubricate. Then it must be pulled up again.

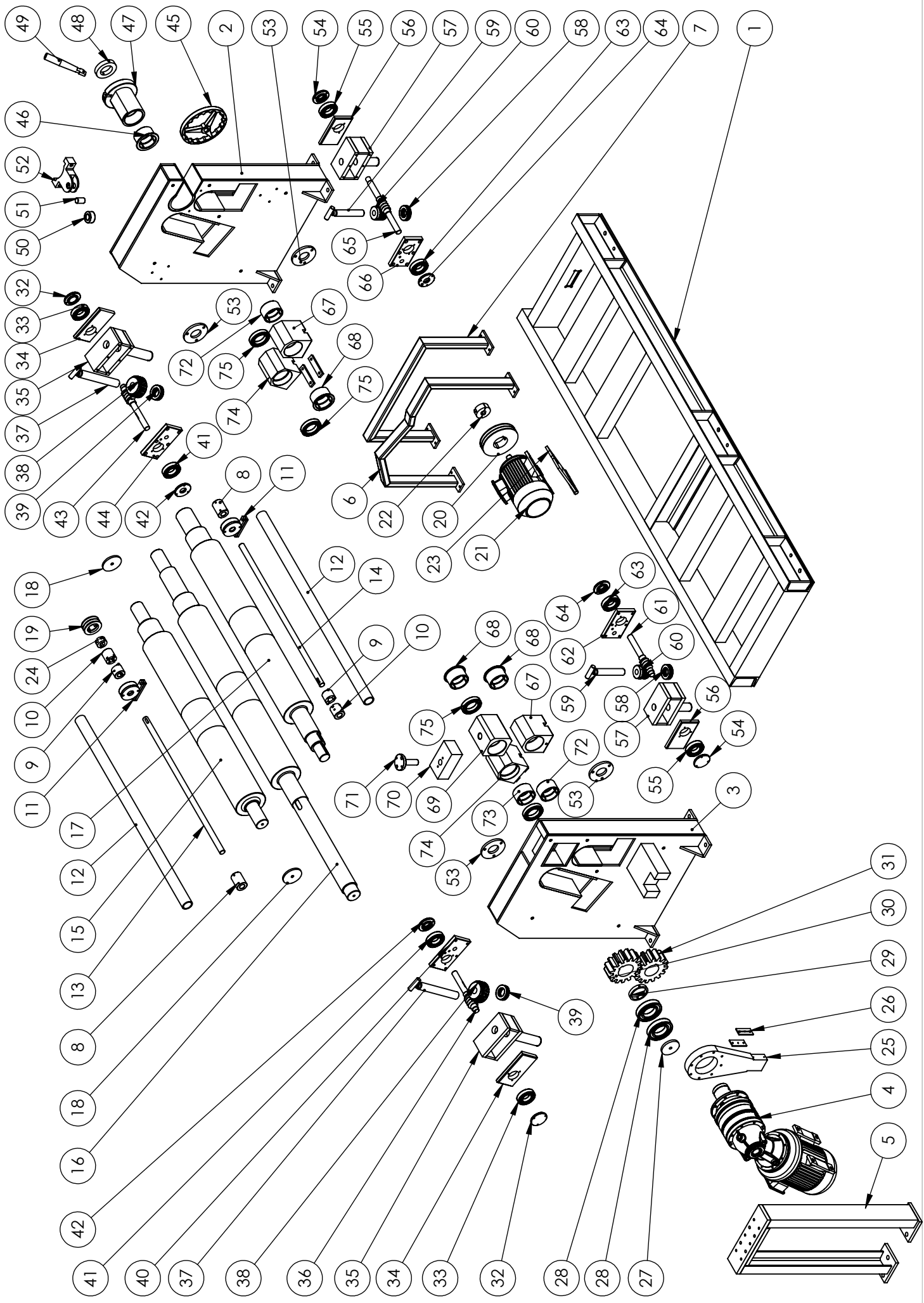

MRM-S PART LIST

part #	Description	part #	Description
1	Lower FRAME	39	Roller
2	Drop-End side FRAME	40	Rear Gear Box Cover
3	Motor Side FRAME	41	Bearing
4	PDA Gearbox (reducer)	42	Bearing Cover
5	TOP ROLL CARRIER Group	43	Worm Screw Shaft
6	Central Sheet Carrier Profiles	44	Rear Gear Box Cover
7	Sheet Carrier Profiles	45	Flip Wheel
8	Transmission Joint	46	Bearing Front Bushing
9	Male Coupling	47	Eccentric Housing
10	Female Coupling	48	Eccentric Ring
11	Roll Support	49	Eccentric Arm
12	Transmission Shaft	50	Support Bearing
13	Back roll Lifting Shaft	51	Conical Device Pin
14	Bottom roll Lifting Shaft	52	Conical Device
15	BACK ROLL	53	Pipe Connection Flange
16	TOP ROLL	54	Bearing Cover
17	BOTTOM ROLL	55	Bearing
18	Side Bearing Cover	56	Front Gear Box Rear Cover
19	V Belt Pulley	57	Front Gear Box
20	Engine V Belt Pulley	58	Bearing
21	Engine	59	Travel Screw
22	Conical Crimping	60	Gear
23	Motor Carrier Plate	61	Worm Screw Shaft
24	Conical Crimping	62	Front Box Cover
25	Reducer Carrier Plate	63	Bearing
26	Fiber	64	Bearing Cover
27	Support Bearing Cover	65	Worm Screw Shaft
28	Bearing	66	Front Box Cover
29	Straight Gear Clamping Ring	67	Lower Housing
30	Top Roll Module Gear	68	Bearing Front Bushing
31	Bottom Roll Module Gear	69	Upper Bushing
32	Bearing Cover	70	Upper Bushing Clamping Chock
33	Roller	71	Upper Bushing Clamping Pin
34	Side Gear Box Rear Cover	72	Lower Bushing Rear Bush
35	Side Gear Box	73	Upper Bushing Rear Bush
36	Worm Screw Shaft	74	Rear Bushing
37	Travel Screw	75	Bearing
38	Gear		